



Sensis is a smart Thermal Management device for enclosure that meets alone all the needs of climate control, predictive maintenance and inter-connectivity. Sensis measures the temperature and humidity inside the enclosure, registers the exceeding of critical thresholds or the opening of cabinet door, as well as interacts with the main field buses or the network.

Technical data		
APPROVALS		
Approvals	CE; cULus	
ELECTRICAL DATA		
Max Relè Output Voltage	250	V a.c.
Rated Voltage	24	V d.c.
Rated Current	150	mA
Rated Power	3.6	W
Operating Voltage	21.6-26.4	V d.c.
Appliance Class	II	
Max Contact Current	8	A
GENERIC DATA		
Protocol	Modbus/TCP	
Accuracy	± 3.5	% RH
Accuracy	± 1	K
Casing Material	PC/ABS	
RAL Number	7035	
Sensor Type	Electronic	
Setting Range	0÷50	°C
	32÷122; 32÷210	°F
Setting Range	0÷99	% RH
Setting Resolution	1	°C
	34	°F

Image is for illustrative purpose only. All specifications, data and drawing are subject to change without notice. Please refer to our terms of sales including our warranty and limited liabilities clauses.

Kontakt Daten für Anfragen und Bestellungen:

MBI GmbH • Ubstadter Pfad 5 • 76694 Forst

Tel. 0049 7251/3020408 • Fax 0049 7251/3020409 • E-Mail: info@mbi-gmbh.de • Web: www.mbi-gmbh.de

Technical data		
Electrical Connection	Terminal Block	
Rated Differential	± 2	% RH
Rated Differential	± 2	K
Wires Section	22-12	AWG
Wires Section	0.5-2.5	mm ²
Fixing System	DIN rail	
ENVIRONMENTAL AND THERMAL DATA		
IP Protection Degree	IP20	
Operating Temperature	-10÷55	°C
	14÷131	°F
Storage Temperature	-25÷70	°C
	-13÷158	°F
Max Humidity	99	% RH
UL DATA		
UL File Number Listed	E504624	

Image is for illustrative purpose only. All specifications, data and drawing are subject to change without notice. Please refer to our terms of sales including our warranty and limited liabilities clauses.

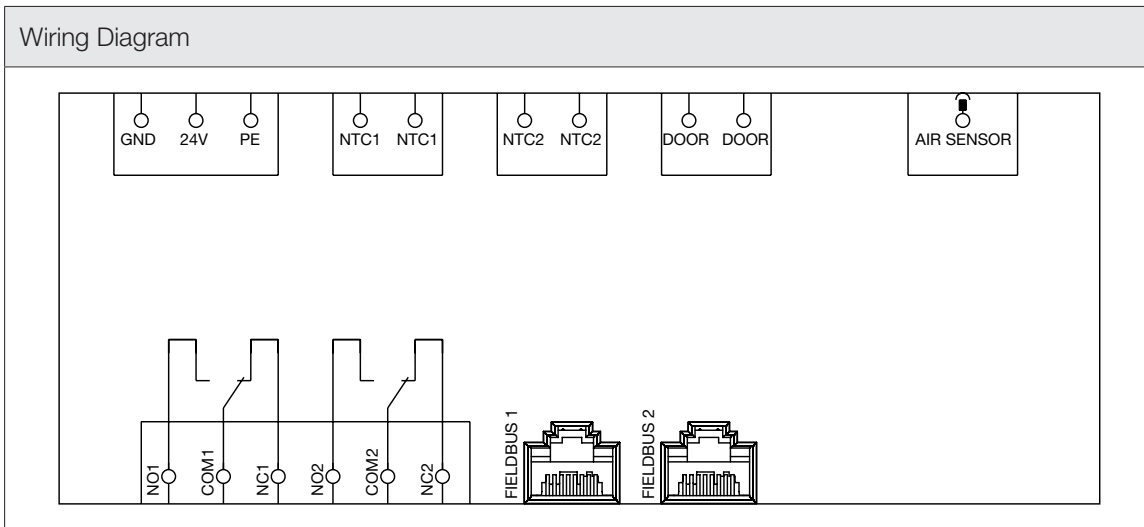
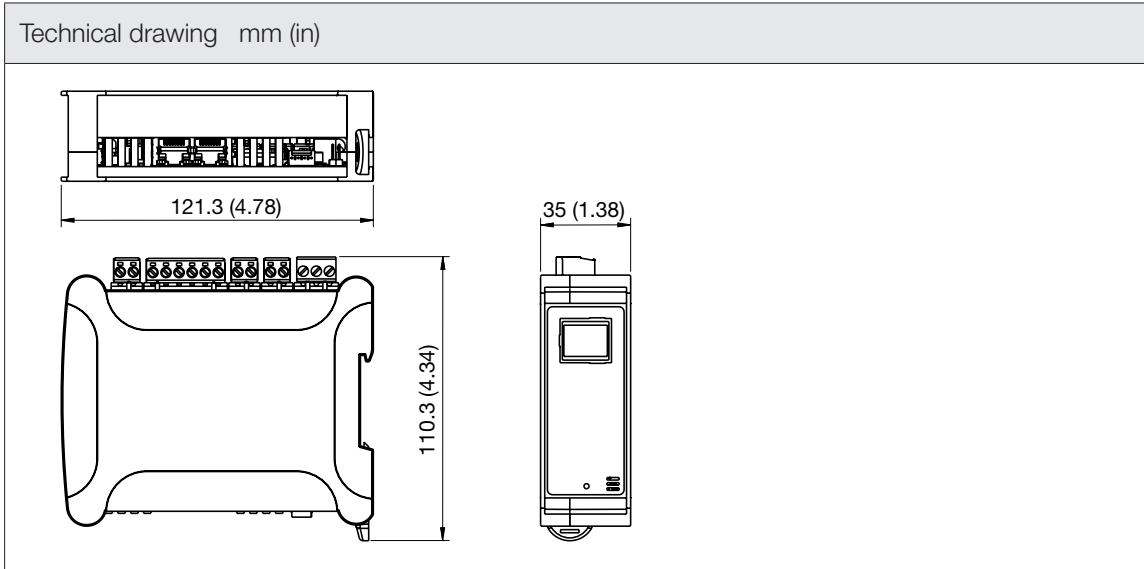

Image is for illustrative purpose only. All specifications, data and drawing are subject to change without notice. Please refer to our terms of sales including our warranty and limited liabilities clauses.